

POF SOLUTION

Plank Optical Fiber Receiver Module

Plank Optoelectronics Inc. is a professional developer and manufacturer of fiber optical communication components that deploy high-capacity broadband communications networking with advances in fiber Optics technologies. Based on our long-term researching and improving on Optoelectronics field, we are capable of providing optical fiber transmitter/receiver modules for a variety of fiber optical applications.

FEATURES

- | High speed up to 13.2 Mbps, (NRZ signal)
- | High sensitivity for red light
- | +5V power source
- | Low power consumption and current dissipation
- | Low jitter



PKRX3012

APPLICATIONS

- | Audio digital amplifiers
- | Mother Board
- | PC, Notebook
- | Sound card
- | DVD, CD, MD players

DIMENSIONS (Unit : mm ; Tolerance : ±0.3mm)

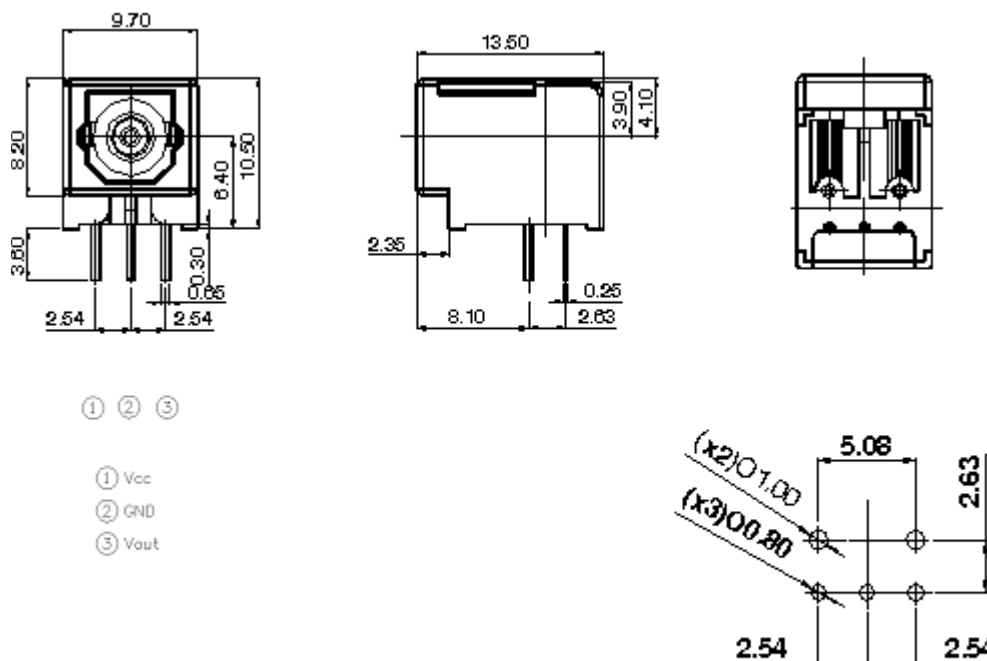

① ② ③

- ① Vcc
- ② GND
- ③ Vout

PCB LAYOUT

ABSOLUTE MAXIMUM RATINGS(Based on room temperature, $T_a=25^{\circ}\text{C}$)

ITEM	SYMBOL	RATING	UNIT
Supply Voltage	Vcc	6.0	V
Output Voltage	Vo	Vcc+0.3	V
Operating Temperature	Topr	-20 to 70	$^{\circ}\text{C}$
Storage Temperature	Tstg	--30 to 85	$^{\circ}\text{C}$
Soldering Temperature	Tsol	260*	$^{\circ}\text{C}$

* Soldering time : 5sec/2times.

RECOMMENDED OPERATING CONDITIONS

ITEM	SYMBOL	CONDITION	MIN.	TYP.	MAX.	UNIT
Supply voltage	Vcc	--	4.75	5.00	5.25	V

ELECTRO-OPTICAL CHARACTERISTICS (On condition : $V_{cc}=5.0\text{V}$, $T_a=25^{\circ}\text{C}$)

ITEM	SYMBOL	CONDITION	MIN.	TYP.	MAX.	UNIT
Optical power input sensitivity	Pi	-	24	-	-14	dBm
Data Rate	T	NRZ signal	100K ⁽¹⁾	-	13.2	Mbps
Peak Sensitivity Wavelength	λ_p	-	-	650	-	nm
Current consumption	Icc	Ref. to method.1	-	4	6	mA
High Level output Voltage	Voh	Ref. to method.2	2.4	4.8	-	V
Low Level output Voltage	Vol	Ref. to method.2	-	0.2	0.4	V
Rise time	tr	Ref. To method.2	-	8	20	ns
Fall time	tf	Ref. to method.2	-	8	20	ns
Low•High propagation delay	tPLH	Ref. to method .2	-	-	100	ns
High•Low propagation delay	tPHL	Ref. to method .2	-	-	100	ns
Pulse Width Distortion	Δtw	Ref. to method. 2	-20	-	20	ns
Jitter	Δtj	Ref. to method .3	-	1	10	ns

* Output voltage level will be unstable if input signal < 100Kbps.

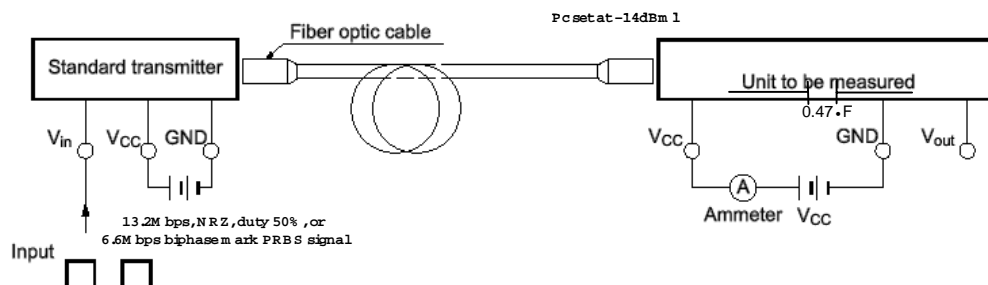
MEASURING METHOD 1.Note 1. Setting the fiber coupling light output power at $P_c = -14\text{dBm}$, $V_{cc} = 5.0\text{V}$

Note 2. The standard transmitter input signal: 13.2Mbps NRZ.

Note 3. Setting the ampere meter at DC average amperage.

MEASURING METHOD 2.

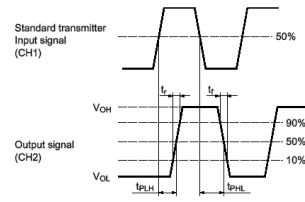
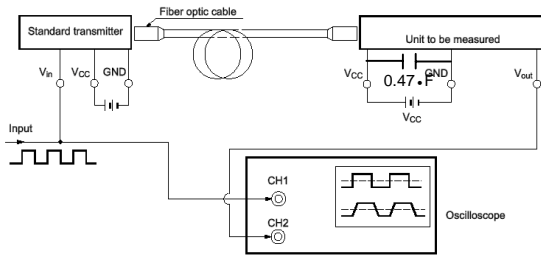

- Note 1. Operating power : $V_{cc} = 5.00V \pm 0.05V$
- Note 2. Set the fiber coupling light output power at 14dBm/-24dBm.
- Note 3. The standard transmitter input signal : 13.2Mbps NRZ.

MEASURING METHOD 3.

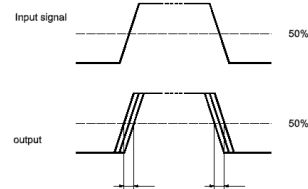
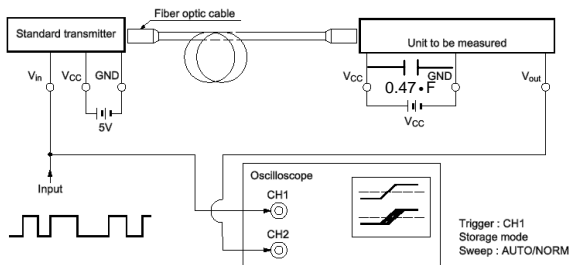

- Note 1. Operating power : $V_{cc} = 5.00V \pm 0.05V$
- Note 2. Set the fiber coupling light output power at 14dBm/-24dBm.
- Note 3. The standard transmitter input signal : 6.6Mbps biphase mark PRBS signal.

RELIABILITY TEST

	ITEM	TEST CONDITION	FAILURE/SAMPLE
1	High temp. storage	Ta=80°C, 500h	0/22
2	Low Temp. storage	Ta=-30°C, 500h	0/22
3	High temp. operation	Ta=60°C, Vcc=5.0V, 500h	0/22
4	High temp. & Hum. storage	Ta=40°C, 90%RH, 500h	0/22
5	Temp. cycling	Ta=-30°C (30min) ~ (1hr)~ 80°C (30min), 20 cycles	0/22
6	Shock	Acceleration 100G(980m/s ²), pulse width 6ms, X,Y,Z/3 times each direction.	0/11
7	Vibration	10~55Hz sweep 1 min, amplitude: 1.5mm, X,Y,Z/2hours	0/11
8	Terminal strength (Tension)	Weight: 5N, 30s/each terminal.	0/11
9	Terminal strength (Bending)	Weight: 2.5N(In the axial direction), 0°→90°→0°, 2 times/each terminal.	0/11
10	Soldering Heat	Solder bath method, Ta=260°C ±10°C, 5s, 2 times. Thickness of print circuit board: 1.6mm. Solder iron method. Ta=350°C, 3s, 1 time. Soldering at the place more than 7mm away from the center a lens.	0/11
11	Solder ability	Soldering at the place more than 3mm away from the foot of the terminal. Used as rosin flux.	0/11

Above testing results are based on ambient temperature : 5°C ~35°C, relative humidity : 45%~85%. The results of item 1 to 5 and 10 was collected at 2 hours normal temperature and humidity after the testing.)

JUDGE CRITERIA

In the item 1 to 7 and 10, electro-optical characteristics must meet following table.

Upper limit less than x1.2 Lower limit greater than x0.8	Upper limit less than x0.8 Lower limit greater than x1.2	Upper limit less than x1.2 Lower limit greater than x1.2
(1) Current consumption (2) Propagation delay time (3) Jitter	(1) High Level Output Voltage (2) Low Level Output Voltage	Pulse Width Distortion

Item 8, 9 : Without cracks to the terminal.

Item 11 : A new uniform coating of solder shall cover a minimum of 3/4 of the surface being immersed.

APPLICATION NOTES:

Optical Fiber Receiver Module PCB layout for motherboard integration

In order to achieve better jitter and low input optical power performances, several PCB layout guidelines must be followed. These guidelines ensure the performance of the receiver module for the motherboard integration. Failed to implement these PCB guidelines may affect the receiver module jitter and low input power performances

- Careful decoupling of the power supplies is very important. Place a 0.47•F surface mount (size 805 or smaller) capacitor as close as (less than 1cm) to the POF Vcc and GND leads. The 0.47 •F act as a low impedance path to ground for any stray high frequency transient noises.
- To reduce the digital noises form the digital IC the motherboard, the planar capacitance formed by an isolated Vcc and GND planes is critical. The receiver module device must be mounted directly on these two planes to reduce the lead parasitic inductance.
- The isolated Vcc and GND planes must be connected to the main Vcc and GND (digital) planes at a single point using ferrite beads. The beads are used to block the high frequency noises from the digital planes while still allowing the DC connections between the planes (see Figure A. below).

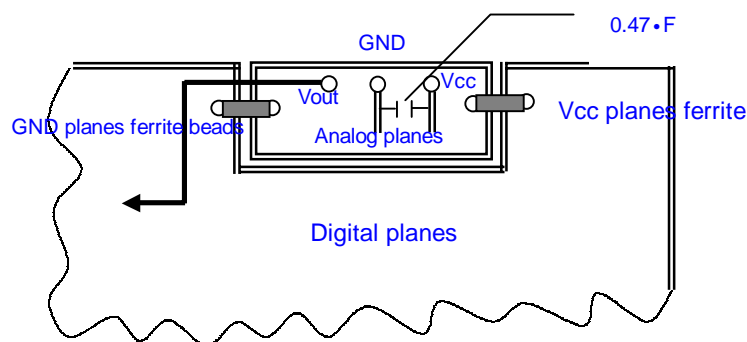

Receiver Module PCB layout for motherboard integration